

Intelligent Electrochemical Sensor Gas Detectors

DESCRIPTION

Panterra-ECHEM is a series of trace gas detectors based on electrochemical sensor technology for applications requiring accuracy, sensitivity and selectivity. These sensors are intended for ambient safety applications.

TARGET GASES

Oxygen

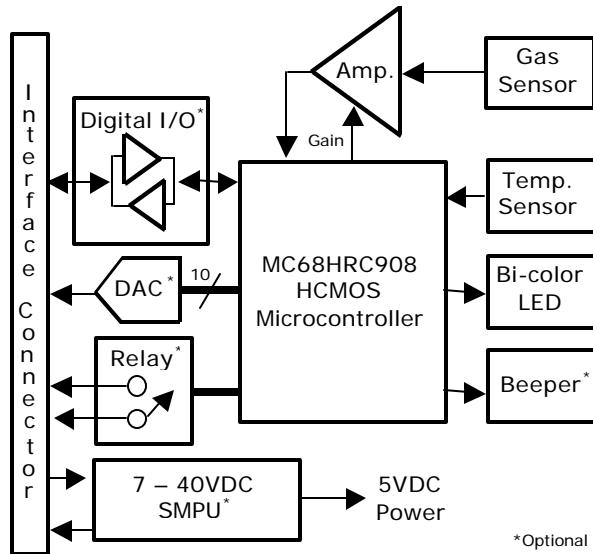

SPECIFICATIONS (Preliminary and Tentative)

Target Gas	Chem	Range	Res.	Accur.	T90	Temp.	RH%	Life	Warranty
Oxygen	O ₂	0-30%	0.1%	2%	15s	-20-50	0-99	2 yrs	2 yrs

Note: All sensors rated for atmospheric pressure +/- 10%.
 Operating temperatures specified in degrees Celsius.
 Accuracies specified as percent signal repeatability and linearity error.
 Relative humidity specifications refer to non-condensing environments
 Lifetime specification based on normal operation in air

Panterra-ECHEM Gas Detector

STANDARD FEATURES

Supported states:	Normal, Warning, Alarm, Error
Visual indication:	Bi-color (red/green) LED
Audio indication:	80dB at 30cm beeper (optional)
Relay:	<ul style="list-style-type: none">- 100 VA sealed SPST- NO or NC- Auto reset or manual reset (latching)
Sensor sampling system:	10-bit A/D with auto-ranging analog front end
Temperature compensation:	Active compensation over entire operating range
Output signaling (one of):	
0-5VDC:	8 or 10-bit DAC (optional)
TTL:	Normally high/low – Auto/Latching (optional)
Step function:	Voltage encoded Normal, Warning, Alarm, Error (optional)
Digital communications:	PK-Port™ compliant signaling for calibration and monitoring
Input power:	
I1:	5VDC regulated
I2:	7-40VDC unregulated
I3:	7-60VDC unregulated
Mechanical:	<ul style="list-style-type: none">- 2.5" x 2.0" x 1.0" form factor- Anodized aluminum enclosure optional- Extendable sensor: 25' cable, 1" x 1" x 1" sensor head
General:	<ul style="list-style-type: none">- User-settable alarm/warning via <i>PK-Port™</i>- Digital FLASH-based calibration- Each device factory pre-calibrated- Field re-programmable firmware

SPECIAL FEATURES

Error detection:	Temperature error (signal as Alarm or Error state)
Power consumption:	100mW

ORDERING OPTIONS

Target gas:	O ₂
Action levels:	Warning and alarm concentration as percentage of range
Output signal type:	None, 0-5VDC, TTL – norm. hi/lo – auto/latch, step function
Relay type:	None, norm. open/closed – auto/latch
Beeper:	None, included
Operating voltage:	5VDC, 7-40VDC, 7-60VDC
Enclosure:	None (open frame), anodized aluminum