

Intelligent Catalytic Sensor Gas Detector

DESCRIPTION

Panterra-CAT-H₂ is a hydrogen gas detector based on catalytic sensor technology. The sensor can withstand high concentrations of hydrogen without permanent damage.

TARGET GAS

- Hydrogen

BLOCK DIAGRAM

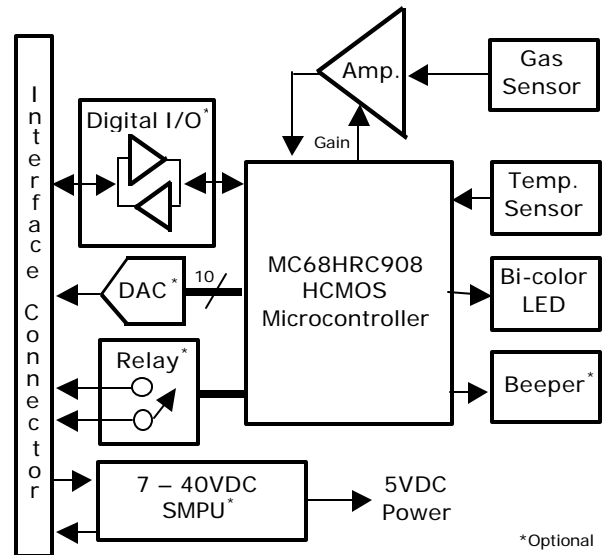

SPECIFICATIONS (Preliminary and Tentative)

Parameter	Min	Typ	Max	Unit
Sensing range	-	-	40,000	PPM
Sensing Resolution	-	100	-	PPM
Accuracy	+/- 1,000	+/- 500	-	PPM
Start-up time	-	10	-	Secs.
Response time (T90)	-	10	20	Secs.
Recovery time (T10)	-	10	20	Secs.
Relative humidity	0	-	95	% R.H.
Operating temperature	-10	-	+60	Deg. C.
Altitude/pressure	0.8	-	1.2	Atmos.
Atmospheric oxygen	2	21	-	% vol.
Flow rate	-	-	1	m/sec.

Note: Accuracy specification includes repeatability and linearity error.
Relative humidity specification refers to non-condensing environments

Panterra-CAT-H₂ Gas Detector

STANDARD FEATURES

Supported states:	Normal, Warning, Alarm, Error
Visual indication:	Bi-color (red/green) LED
Audio indication:	80dB at 30cm beeper (optional)
Relay:	<ul style="list-style-type: none">- 100 VA sealed SPST- NO or NC- Auto reset or manual reset (latching)
Sensor sampling system:	10-bit A/D with auto-ranging analog front end
Temperature compensation:	Active compensation over entire operating range
Output signaling (one of):	
0-5VDC:	8 or 10-bit DAC (optional)
TTL:	Normally high/low – Auto/Latching (optional)
Step function:	Voltage encoded Normal, Warning, Alarm, Error (optional)
Digital communications:	PK-Port™ compliant signaling for calibration and monitoring
Input power:	
I1:	5VDC regulated
I2:	7-40VDC unregulated
I3:	7-60VDC unregulated
Mechanical:	<ul style="list-style-type: none">- 2.5" x 2.0" x 1.0" form factor- Anodized aluminum enclosure optional- Extendable sensor: 25' cable, 1" x 1" x 1" sensor head
General:	<ul style="list-style-type: none">- User-settable alarm/warning via <i>PK-Port™</i>- Digital FLASH-based calibration- Each device factory pre-calibrated- Field re-programmable firmware

SPECIAL FEATURES

Error detection:	Temperature error (signal as Alarm or Error state)
Power consumption:	1W
Sensor lifetime:	5 years

ORDERING OPTIONS

Action levels:	Warning and alarm concentration as percentage of range
Output signal type:	None, 0-5VDC, TTL – norm. hi/lo – auto/latch, step function
Relay type:	None, norm. open/closed – auto/latch
Beeper:	None, included
Operating voltage:	5VDC, 7-40VDC, 7-60VDC
Enclosure:	None (open frame), anodized aluminum