

Catalytic Hydrogen Gas Monitor

FEATURES

- Catalytic Sensor & HCMOS microcontroller
- 0-25,000 ppm hydrogen in air measurement
- 100 ppm logical resolution (120 ppm: 4-20mA)
- 2 seconds start-up time
- 2 secs. T90 response time
- 5 secs. T10 recovery time
- Normal, Warning, Alarm & Error states
- Bi-color LED status indicator
- Optional NO or NC dry relay
- Manual reset or auto-resetting operation
- Optional 0-to-3V proportional output (8 bit)
- Optional 4-20mA proportional output (8 bit)
- Optional binary operation (TTL output)
- Optional alarm beeper
- *PK-Port™* compatible digital communications
- User-settable alarm/warning via *PK-Port™*
- Digital FLASH-based calibration
- Each device factory pre-calibrated
- Field re-programmable firmware
- -40 to +80 Celsius operation
- Sensor & temperature error detection
- 100mW power consumption
- Optional 3VDC input power version (I1)
- Optional 5-40VDC input power version (I2)
- Optional 5-60VDC input power version (I3)
- 61mm x 48mm x 26mm circuit-only size



DESCRIPTION

The Neodym HydroKnowz™ is an intelligent hydrogen gas monitor intended for safety applications in power generation equipment. The sensor has a VOC filter, cannot be damaged by overexposure and has increased tolerance of silicone-based contaminants. Linear measurement of hydrogen (in air) concentrations is possible up to 25,000 ppm with about 100 ppm resolution. Each device is factory calibrated to a user-specified alarm point. Calibration values are FLASH memory-based and are field-adjustable via Neodym's *PK-Port™* PC interface. The device operates at 3VDC and consumes about 1000mW. Wide input supply versions are available. Custom form factors, connector types and mounting provisions are available by special order.

BLOCK DIAGRAM

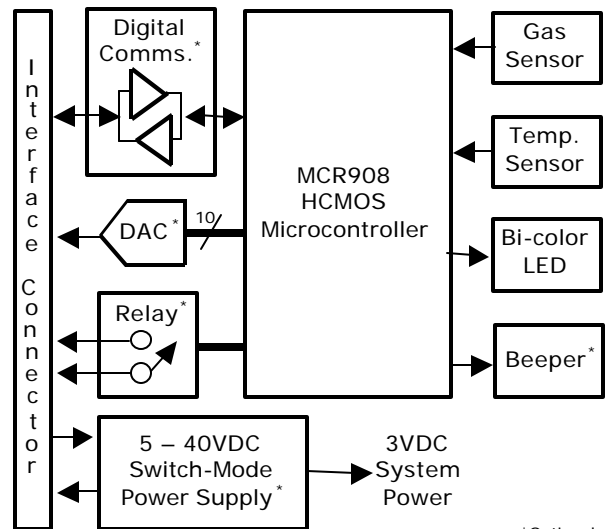

1 - FUNCTIONAL DESCRIPTION

1.1 - OVERVIEW

Neodym HydroKnowz™ gas monitors comprise of an HCMOS microcontroller, a catalytic gas sensing element and amplifier, a semiconductor temperature sensor, a bi-color indicator LED and various optional signaling devices such as an alarm beeper, dry relay and D-to-A converter (or 4-20mA loop driver).

Standard devices operate with 3VDC regulated input power. Wide input supply versions are available that accept 5-40VDC (or 5-60VDC).

A one-wire bi-directional digital interface (*PK-Port™*) may be used for set-up, calibration and remote monitoring via a PC.

Each time that power is applied the device enters a brief warm-up state after which active gas sensing functions commence. Gas concentrations and sensing state indications become available after the warm-up period has elapsed.

Gas sensor signals are continuously sampled by an 8-bit A-D subsystem and are digitally filtered to reject burst noise and other spurious events. The filtered signal is then stripped of its baseline component and is spanned according to its memory-resident calibration values. The scaled signal is used to produce linear readings of gas concentration that may be accessed in real-time via the output signal DAC, 4-20mA driver, or the *PK-Port™* interface.

1.2 – SYSTEM COMPONENTS

This section describes the function of various HydroKnowz™ system components. Certain items may not be present depending on the options selected at order time.

SENSOR (Standard)

The employed gas-sensing element is a catalytic type offering high sensitivity to hydrogen, rapid response/recovery time, no “inverted response” at high gas

concentrations, modest power requirements and long life.

The sensor has an in-line VOC filter, good long term stability characteristics, increased tolerance of silicones, and is immune to overexposure damage.

Gas sensing is performed on a diffusion basis and materials that would impede the convection of the sampled atmosphere to the sensor should therefore never obstruct the sensor opening.

RESET BUTTON (Optional)

This user control is used to manually reset a latched relay or TTL output signal. Please see RELAY and TTL OUTPUT SIGNAL.

LED (Standard)

A bi-color (red/green) light-emitting diode is used to provide visual indication of the detector's state. For more details, please see the section titled DEVICE STATES.

BEEPER (Optional)

This piezzo transducer is used to provide audible indication of the detector's state. For more details, please see the section titled DEVICE STATES.

OUTPUT SIGNAL (Optional)

The output signal is accessible via the INTERFACE CONNECTOR. Depending on device options, the output signal may be binary (TTL) or proportional (0-3V or 4-20mA output option).

The TTL output function may be configured at order time (or using *PK-Port™*) as normally high or normally low; latching or auto-resetting. It may further be configured to respond to the Warning level, the Alarm level, or both.

For more details on interpreting the 0-3V and 4-20mA output function, please see the section titled OUTPUT READING.

RELAY (Optional)

This SPST reed relay provides two dry contacts that can be used to switch a modest external load.

The device may be configured at order time (or using PK-Port™) as normally open or normally closed; latching or auto-resetting. It may further be configured to respond to the Warning level, the Alarm level, or both.

Auto-resetting relays return to their normal state after the condition that caused the relay's activation has been removed. Latching relays, once activated, maintain their activation state until deliberately reset via the RESET button (or power cycling).

INTERFACE CONNECTOR (Standard)

This connection permits application of input power and connection to the relay contacts and output signal. For pin details, please see the section titled ELECTRICAL INTERFACE.

1.3 - DEVICE STATES

Five device states are supported, viz. warm-up, normal, warning, alarm and error. Each state asserts specific signaling conditions. EG, devices can be configured to activate the TTL output signal during the warning state and to activate the relay during the alarm state.

WARM-UP STATE

The warm-up state is entered whenever the device is powered-on and lasts approximately 2 seconds. This period permits the gas sensor to reach its proper operating temperature and allows the sensor signal to stabilize after periods of inactivity. During the warm-up state gas sensing is not active and zero value gas readings are returned. The LED blinks green/off during the warm-up period.

NORMAL STATE

The normal state is entered upon the expiry of

the warm-up period. During the normal state the LED remains steady green. The normal state is maintained while the power level is valid and while there is an absence of error conditions or actionable gas concentrations. All other states return to the normal state upon their expiry or resolution.

WARNING STATE

The warning state reports a gas concentration that is a specific percentage of the alarm state. This action percentage is stored in memory and is usually configured at order time. PK-Port™ may be used to modify the action level. During the warning state the LED blinks red/green.

ALARM STATE

The alarm state is entered when the gas concentration reaches or exceeds a predetermined threshold. The action level is stored in memory and is usually configured at order time, although it may be reconfigured using PK-Port™. During the alarm state the LED blinks red/off.

ERROR STATE

The error state is asserted whenever the device is prevented from providing reliable readings. The error sources are gas sensor failure/removal, temperature out of bounds and loss of firmware integrity (detectable via a checksum failure). During the error state gas concentration readings are invalid and return full-scale values for failsafe operation. During the error state the LED remains off and briefly pulses red about every 10 seconds. Normal device operation resumes dynamically when the error condition is resolved.

Please note: The device features a Low Voltage Inhibit function and a Computer Operating Properly watchdog timer. A fault from either source does not produce an error state but rather device reset. If such faults should persist then they are detectable via continuous return to the warm-up state.

TABLE 1.2.1 – Device States Summary

State	Stimulus	Reading	LED	Beeper
Warm-up	Power-on, software error	Zero	Blink green/off	Inactive
Normal	Ambient conditions	Valid	Steady green	Inactive
Warning	Warning threshold reached	Valid	Blink red/green	Inactive
Alarm	Alarm threshold reached	Valid	Blink red	½ second beeps
Error	Sensor failure, temperature error	Full scale	Off, pulse red	10 second beeps

1.4 – OUTPUT READING

Gas concentration indications are available as a proportional output voltage in devices with the 0-3V output option (DAC), or as a proportional output current in 4-20mA models.

1.4.1 – 0 - 3V ANALOG OUTPUT

Devices with a 0-3V output signal (“O5” option) encode the measured gas concentration as one step per 100 ppm hydrogen where each reading step is about 12mV.

The output signal is produced by a 10-bit DAC with a resolution of $3V/1023 \text{ steps} = 2.93255 \text{ mV}$. While the DAC resolution is 10 bits (~25 ppm), the gas reading resolution is 8 bits (100 ppm) – which means that the output signal steps by four DAC units for each 100 ppm (11.73mV).

A 60mV (20 DAC steps) safety offset (trouble threshold) is applied to the output signal and needs to be subtracted when calculating the gas reading. The absence of this offset voltage may be used to indicate a system error condition or that there has been a break/short in the output signal wiring.

OUTPUT VOLTAGE INTERPRETATION

The output signal voltage may be converted to a gas concentration using the following formula:

$$\text{ppm} = ((V_{\text{OUT}} - V_{\text{OFS}}) / \text{StepSize}) \times \text{Resolution}$$

where

ppm is the gas concentration

V_{OUT} is the total output signal voltage

V_{OFS} is the offset voltage (60mV)

StepSize is the reading step size (11.73mV)

Resol. is 100 ppm

For example:

An output signal voltage of 2.23V would be indicating the following gas concentration:

$$\begin{aligned} & ((2.23V - 0.06V) / 0.01173V) \times 100 \text{ ppm} \\ & = 18,500 \text{ ppm} \end{aligned}$$

i.e. 185 net steps of 100 ppm each

1.4.2 – 4 – 20mA ANALOG OUTPUT

Devices with a 4-20mA current loop driver (“O6” option) encode the measured gas concentration as one step per 120 ppm hydrogen where each step is about 0.08mA starting from the 4mA baseline.

The output signal is produced by a 10-bit DAC with a resolution of $20mA/1023 \text{ steps} = 0.01955 \text{ mA}$. While the DAC resolution is 10 bits (~30 ppm), the gas reading resolution is 8 bits (120 ppm) – which means that the output signal steps by four DAC units for each 120 ppm (0.0782mA).

OUTPUT CURRENT INTERPRETATION

The output signal current may be converted to a gas concentration using the following formula:

$$\text{ppm} = ((I_{\text{OUT}} - I_{\text{OFS}}) / \text{StepSize}) \times \text{Resolution}$$

where

ppm is the gas concentration

I_{OUT} is the total output signal current

I_{OFS} is the offset current (4mA)

StepSize is the reading step size (0.782mA)

Resol. is 120 ppm

For example:

An output signal current of 9.865mA would be indicating the following gas concentration:

$$\begin{aligned} & ((9.865\text{mA} - 4\text{mA}) / 0.0782\text{mA}) \times 120 \text{ ppm} \\ & = 9,000 \text{ ppm} \end{aligned}$$

i.e. 75 net steps of 120 ppm each

LOOP RESISTANCE & SUPPLY VOLTAGE

The loop resistance (conversely, the input supply voltage) must be chosen such that the full expected load voltage could develop at full-scale deflection.

The loop driver dropout voltage is 2VDC, and thus the input supply voltage must exceed the expected load voltage by at least this amount. EG, for a 750 Ohm load resistor to develop a 15VDC load voltage at 20mA the input supply voltage must be at least 15VDC + 2VDC = 17VDC. It follows that lower resistance loops permit lower input supply voltages.

1.5 – SENSING PERFORMANCE

Sensing performance is only guaranteed over the range of electrical and environmental conditions cited in the specifications sections.

The following remarks are provided for general guidance.

ACCURACY

Sensing accuracy is dependent on proper device calibration and the absence of abusive handling. Please see the Use, Care & Maintenance section for recommended handling and usage procedures.

Accuracy is defined as the ability of the sensor to correctly indicate the real gas concentration – whether from the point of view of short-term repeatability or long-term stability.

The specified accuracy error budget takes into account the following factors: Sensor, amplifier, A-to-D, and D-to-A linearity; Supply voltage variation; Sensing and calibration resolution; Sampling jitter due to electrical noise; Math rounding-off errors.

RESPONSE TIME

Whereas the raw gas signal response and recovery time is virtually immediate, the system employs software averaging and hysteresis to filter out spurious events and to prevent metastable indications. Please refer to the Electrical Specifications section for these AC characteristics.

CALIBRATION

All devices are individually factory calibrated prior to delivery. Calibration is performed digitally with values stored in FLASH memory. Baseline offsets (zero) may be captured via PK-Port™. User modification of the Span value may be performed via the PK-Port™ interface and requires exposure of the device to calibration reference gas in a chamber of known volume.

1.6 – PERFORMANCE SPECIFICATIONS

Note: The following parameters apply under the Functional Operating Conditions stipulated in the Electrical Specifications section.

TABLE 1.6.1.1 – Hydrogen sensing characteristics

Parameter	Min	Typ	Max	Unit	Note
Sensing range					
0-3VDC output signal models:	-	-	25,000	ppm	
4-20mA output signal models:	-	-	24,500		
Logical resolution					
0-3VDC output signal models:	-	-	100	ppm	
4-20mA output signal models:	-	-	120		
Accuracy	5	3	-	%	1
Linearity	5	3	-	%	2
Air velocity error	-	1	1.5	%	4
HMDS tolerance	100/50 10/500	-	-	PPM/hrs	
Start-up time	-	2	10	Sec.	
Response time (T90)	-	2	3	Sec.	
Recovery time (T10)	-	5	10	Sec.	

TABLE 1.6.1.2 – Hydrogen sensing environmental requirements

Parameter	Min	Typ	Max	Unit	Note
Relative humidity	0	-	99	% R.H.	3
Operating temperature	-40	-	+80	Deg. C.	
Flow rate	-	-	3	m/sec.	4
Atmospheric oxygen	5	21	-	% vol.	

- Notes: 1. Accuracy specified at 8,000 PPM. Please see Sensing Performance for error budget items.
 2. Linearity specified at 4,000 PPM
 3. Non-condensing
 4. Devices are factory calibrated in static air flow conditions

1.7 – RELIABILITY FEATURES

Various fault detection features have been implemented to provide indication of unacceptable sensing conditions. Devices are configured at order time (or via *PK-Port™*) to respond to error conditions by simply asserting the error state, or by triggering the alarm state.

SENSOR ERROR

This error is triggered by the removal of the sensor, or a break in the heater and/or electrode circuits. The error state is released when the sensor is replaced.

TEMPERATURE ERROR

This error is triggered when the operating temperature is above or below permissible levels. The error state is released automatically when the temperature returns to the acceptable range.

COP TIME-OUT

Electrostatic discharges or other electrical events that may alter system RAM and cause improper program operation will cause the Computer Operating Properly watchdog timer to reset the system (return to the warm-up state).

LOW VOLTAGE INHIBIT

The device will remain in the reset state if the supply voltage is below 2.6 VDC (nominal). Low system voltage inhibits the TTL output signal and relay, which may be used for power failure detection. Unstable system power levels manifest themselves as a continuous return to the warm-up state.

MEMORY CHECKSUMS

Abnormal electrical conditions that may cause

a loss of integrity of the FLASH memory are detected via checksum calculations after each power-up. If the firmware checksum value is incorrect then the system will remain in the error state. A similar check and response applies to calibration and configuration values. Damaged firmware is in-circuit field reprogrammable via *PK-Port™* adapters and a Neodym utility program.

BOUND OFFSET VALUE

The system prevents “zeroing-to-death” conditions by rejecting attempts to capture an offset in high gas concentrations.

1.8 – USE, CARE & MAINTENANCE

HydroKnowz™ sensors can provide reliable readings for many years if properly handled and maintained. To derive the maximum serviceable lifetime from the device, please observe the following recommendations.

CHECK CALIBRATION PRIODICALLY

Although the devices feature several self-diagnosing functions, the only direct method to check accuracy and proper operation is via exposure of the sensor to a reference gas concentration and observing it to read correctly. Devices are delivered factory calibrated, but the accuracy of the unit can and will degrade over time – especially if used in corrosive or hostile environments. It is recommended that calibration checking should be performed as often as is practical and no less frequently than once every six months.

GENERATING REFERENCE GAS

The recommended method for generating calibration test gas mixtures is to dilute pure target gas with clean, normal air in a leak-free chamber of fixed, known volume. A simple procedure is to inject a specific amount of pure target gas using a syringe into a sealed plastic lunch container. EG 50cc of pure target

gas injected into a chamber with a net volume of 5 liters produces a concentration of 10,000 ppm. Gentle shaking or an enclosed fan may be used to assure proper dispersion of the gas mixture. In applications where it is impractical to immerse the module in such a gas mixture, a pump or aspirator may be used to flow the gas mixture over the sensor.

INTERFERENCE GAS

The employed catalytic sensor is not specific to any one combustible gas. Detectors calibrated for (EG) hydrogen applications will read accurately in the presence of homogeneous hydrogen gas/air mixtures, but will also produce readings in the presence of other organic vapors. Heterogeneous gas mixtures generally have a synergistic effect on the sensor, and in the absence of a target gas presence, the interference gases will manifest themselves as 'false' readings.

AVOID SENSOR OBSTRUCTION

The sensor samples the atmosphere based on the diffusion of gas through the filter/mesh into the internal cavity. Please locate the sensor such that it is not pressed against a surface that will obstruct gas flow, and prevent materials such as dust and lint from clogging the sensor mesh.

PROPER PLACEMENT

For earliest warning of a possible gas hazard, locate the detector nearest to the most likely source of the gas leak.

AVOID EXPOSURE TO SILICONE VAPORS

Sealants such as caulking compounds, hoses, etc. may contain silicones. These items may continue to off-gas silicone vapors indefinitely, even after full curing – and especially under high temperature conditions. Extra care should be taken when testing the sensor in

environmental chambers – many of which use silicones for thermal insulation. While the sensor has higher resistance to silicone poisoning than many other catalytic sensors, concentrations of silicone higher than those specified as permissible may lead to a loss of hydrogen sensitivity.

OTHER DELETERIOUS AGENTS

Avoid exposure to corrosive gases such as halogenated solvents and refrigerant gases. As with elemental halogen family gases, they can corrode the sensor, lead to short-term poisoning, and reduce the sensor lifetime.

Avoid exposure to other corrosive environments such as salt-containing sea spray. For coastal and marine applications, modules are available with acrylic conformal coating to preserve circuit lifetime. However, the buildup of a salt crust over the sensor mesh will impede gas diffusion and will affect reliability.

NO STRONG ELECTROMAGNETIC FIELDS

While the circuit is relatively low impedance, avoid locating the sensor in the immediate vicinity (<10 cm) of strong and fluctuating field sources such as fans, pumps, motors, RF transmitters, etc. Close proximity to such fields may result in spurious gas readings. Also, make sure that the detector's power supply is adequately decoupled from fluctuations caused by the switching of large external loads.

2 - INTERFACE

2.1 – ELECTRICAL SPECIFICATIONS

ABSOLUTE MAXIMUM RATINGS

Note: Maximum ratings are the extreme limits to which the device can be exposed without permanent damage. The devices are not guaranteed to operate properly at maximum ratings.

TABLE 2.1.1.1 - Absolute Maximum Ratings – 3VDC input models (I1)

Parameter	Symbol	Value	Unit
Supply voltage	V_{CC}	3.1	VDC

TABLE 2.1.1.2 - Absolute Maximum Ratings – 5-to-40VDC/60VDC input models (I2 & I3)

Parameter	Symbol	Value	Unit
Supply voltage	V_{SUP}		VDC
12 Models:		45	
13 Models:		60	

FUNCTIONAL OPERATING RANGE

Note: Sensing accuracy deteriorates rapidly outside the specified operating voltage range. Permanent device damage may occur above the specified operated voltage range.

TABLE 2.1.2 – Operating Range – 3VDC input models (I1)

Parameter	Symbol	Value	Unit
Operating voltage range	V_{CC}	2.9 to 3.1	VDC

TABLE 2.1.2 – Operating Range – 5-to-40VDC/60VDC input models (I2 & I3)

Note: Input supply voltages in the specified range produce a system voltage (V_{CC}) of 3VDC +/- 2%.

Parameter	Symbol	Value	Unit
Operating voltage range	V_{SUP}		VDC
12 Models:		5 to 40	
13 Models:		5 to 60	

TEMPERATURE RATINGS

TABLE 2.1.3 - Temperature Ratings

Parameter	Symbol	Value	Unit
Storage temperature	t_{STG}	-40 to +125	Deg. C.
Operating temperature range	t_{OP}	-40 to +80	Deg. C.

POWER CONSUMPTION

TABLE 2.1.4.1 – Supply current - 3VDC input models (I1)

Parameter	Symbol	Min	Typ	Max	Unit
Supply current ($V_{CC} = 3.0VDC$)	I_{CC}	-	240	260	mA

TABLE 2.1.4.2 – Supply current - 5-to-40VDC/60VDC input models (I2 & I3)

Parameter	Symbol	Min	Typ	Max	Unit
Supply current ($V_{SUP} = 12VDC$)	I_{SUP}	-	80	90	mA

DEVICE RATINGS

TABLE 2.1.5 – Device ratings

Parameter	Symbol	Min	Typ	Max	Unit
Beeper (piezzo) sound level at 30cm		-	78	-	dB
Sealed reed relay (SPST)					
Switch voltage:		-	200	-	VDC
Switch current:		-	0.5	-	A
Carry current:		-	1.2	-	A
Contact resistance:		-	0.15	-	Ohm
Insulation resistance:		-	10^{10}	-	Ohm

DC CHARACTERISTICS

TABLE 2.1.6 – DC Characteristics

Parameter	Symbol	Min	Typ	Max	Unit
TTL high voltage ($I_{LOAD} = -5.0mA$)	V_{OH}	2.0	-	-	V
TTL low voltage ($I_{LOAD} = 5.0mA$)	V_{OL}	-	-	0.2	V
0-3VDC output signal loading	$O5_{LOAD}$	-	-	3	mA
4-20mA output signal loading ¹	$O6_{LOAD}$	750	-	10	Ohm
Low voltage inhibit reset voltage (V_{CC})	V_{LVR}	2.5	2.6	2.7	V
I/O pin capacitance	C_{IO}	10	12	15	pF
I/O pin termination resistors	R_{TERM}	-	10	-	K-Ohm

Notes:

1. To achieve the desired 4-20mA loop voltage based on a particular load resistor value, the input supply voltage must exceed the maximum loop voltage by 2VDC. EG, for a load resistor of 750-Ohm at 20mA to produce 15VDC, the input supply voltage must be 17VDC min.

AC CHARACTERISTICS

TABLE 2.1.7 – AC Characteristics

Parameter	Symbol	Min	Typ	Max	Unit
Fundamental operating frequency	f_{OP}	5.8	7.3	8.7	MHz
Power-on reset time	T_{PRES}	0.9	1	1.1	mS
COP watchdog time-out time	T_{CTO}	29	32	35	mS
COP time-out reset time	T_{CRES}	90	100	110	uS
Warm-up time	T_{WARM}	1.8	2.0	2.2	S
ADC sampling rate	T_{SAMP}	9	10	11	mS
Signal averaging period	T_{AVG}	450	500	550	mS
State debounce period	T_{DEB}	1.8	2	2.2	S
LED blink rate	T_{LBR}	180	200	220	mS
LED pulse on/off rate	T_{LPR}	0.18/9	0.2/10	0.22/11	S

2.2 – INTERFACE CONNECTOR

SIGNAL DEFINITIONS

TABLE 2.2.1 – Input/Output Signals

Name	Description
V_{CC}	Positive 3VDC regulated input voltage (I1 models).
V_{SUP}	Positive unregulated input voltage (I2 & I3 models)
GND	Common power and output signal ground.
V_{OUT}/I_{OUT}	Output signal. Proportional (analog) 0-to-3VDC in “O5” models. Proportional (analog) 4-20mA in “O6” models. TTL output in case of O1/O2/O3/O4 models.
RLY1 & RLY2	Connections to relay’s SPST electrically isolated switch (if relay installed).
PKP	PK-Port™ single-wire bi-directional digital communications port. Connect only to HCTTL compatible PK-Port™ communications adapter, or leave unconnected.

PIN CONNECTIONS

FIGURE 2.2.1 – Pin connections

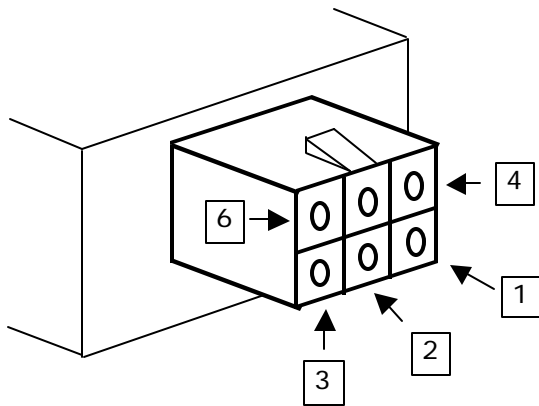

Pin	Symbol	Function
1	V_{CC}/V_{SUP}	Input power (+)
2	GND	Common ground return
3	V_{OUT}/I_{OUT}	Output signal ¹
4	RLY1	Dry relay contact #1 ²
5	RLY2	Dry relay contact #2 ²
6	PKP	PK-Port™ digital I/O ³

Notes: 1. 0-3V, 4-20mA, or TTL – per options
 2. Models with installed relay
 3. Proprietary protocol. Requires adapter.

Connector (shown) part no. 39-29-1068 (Molex)

Mating receptacle part no. 39-01-2060 (Molex)

3.1 – PHYSICAL DIMENSIONS – OPEN FRAME

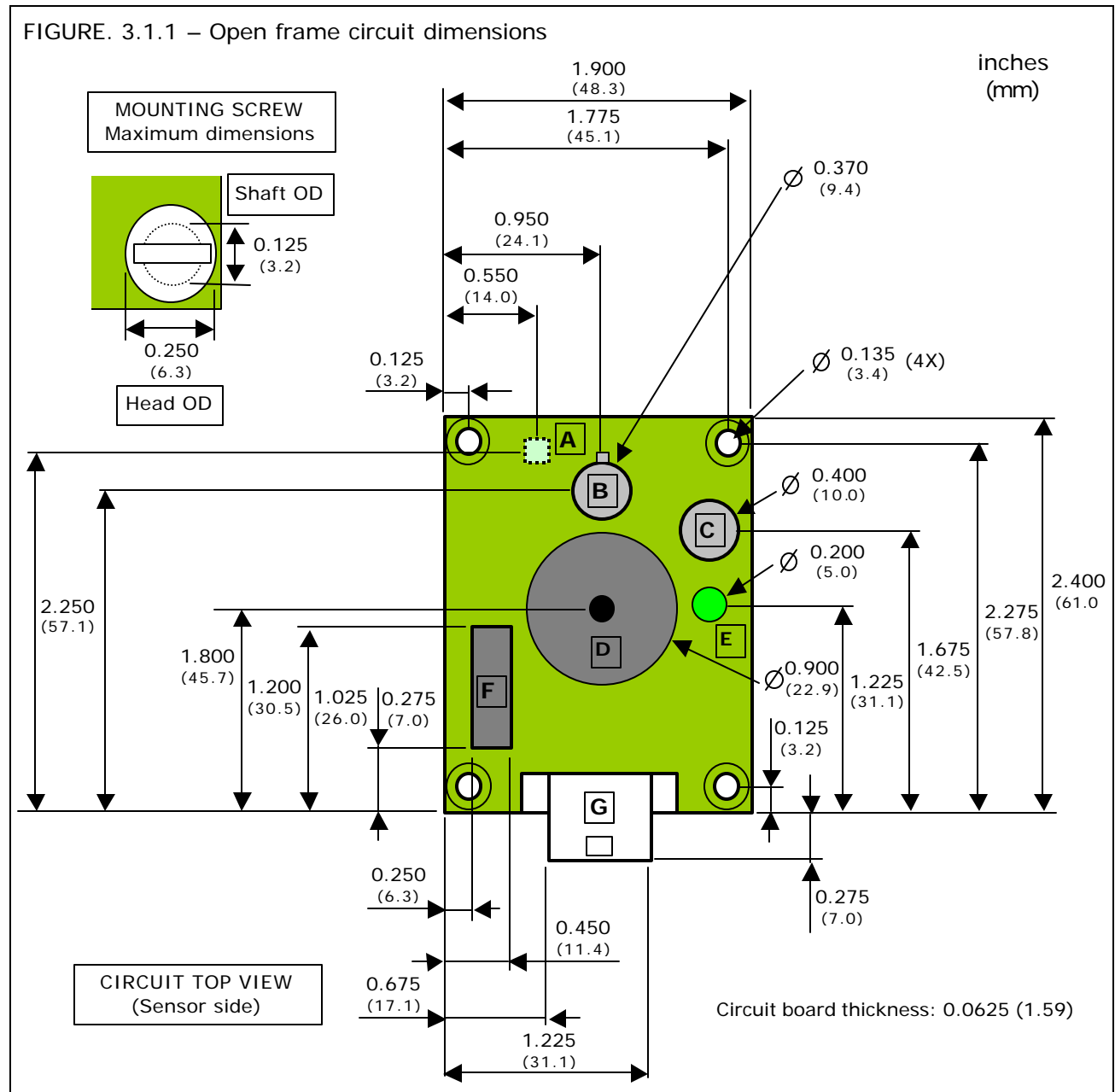

COMPONENT CLEARANCES		SYMBOL	DEVICE	INCHES	MM
The table on the right lists the height above the surface of the circuit board of the indicated components. Allow 0.400 (10.0) below the circuit board for bottom-mounted components. Stand-offs 0.500 (12.7) in length are recommended.		A	Temperature transducer	-0.115	-2.9
		B	Gas sensor	0.45	11.4
		C	Reset pushbutton	0.550	14.0
		D	Beeper	0.375	9.5
		E	LED	0.550	14.0
		F	Relay	0.285	7.3
		G	Interface connector	0.400	10.0

3.2 – PHYSICAL DIMENSIONS - ENCLOSED

FIGURE. 3.2.2.1 – Enclosure dimensions

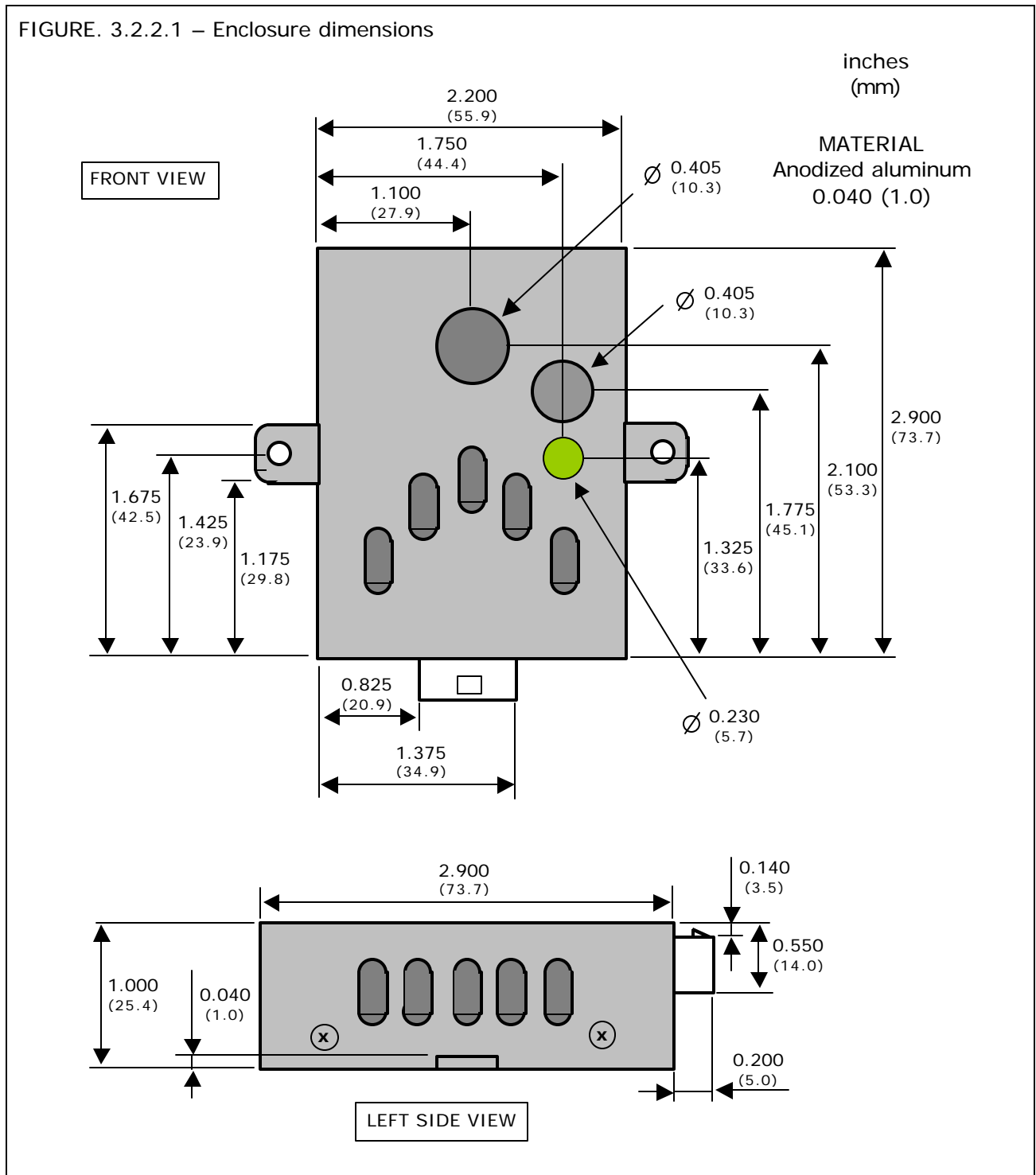
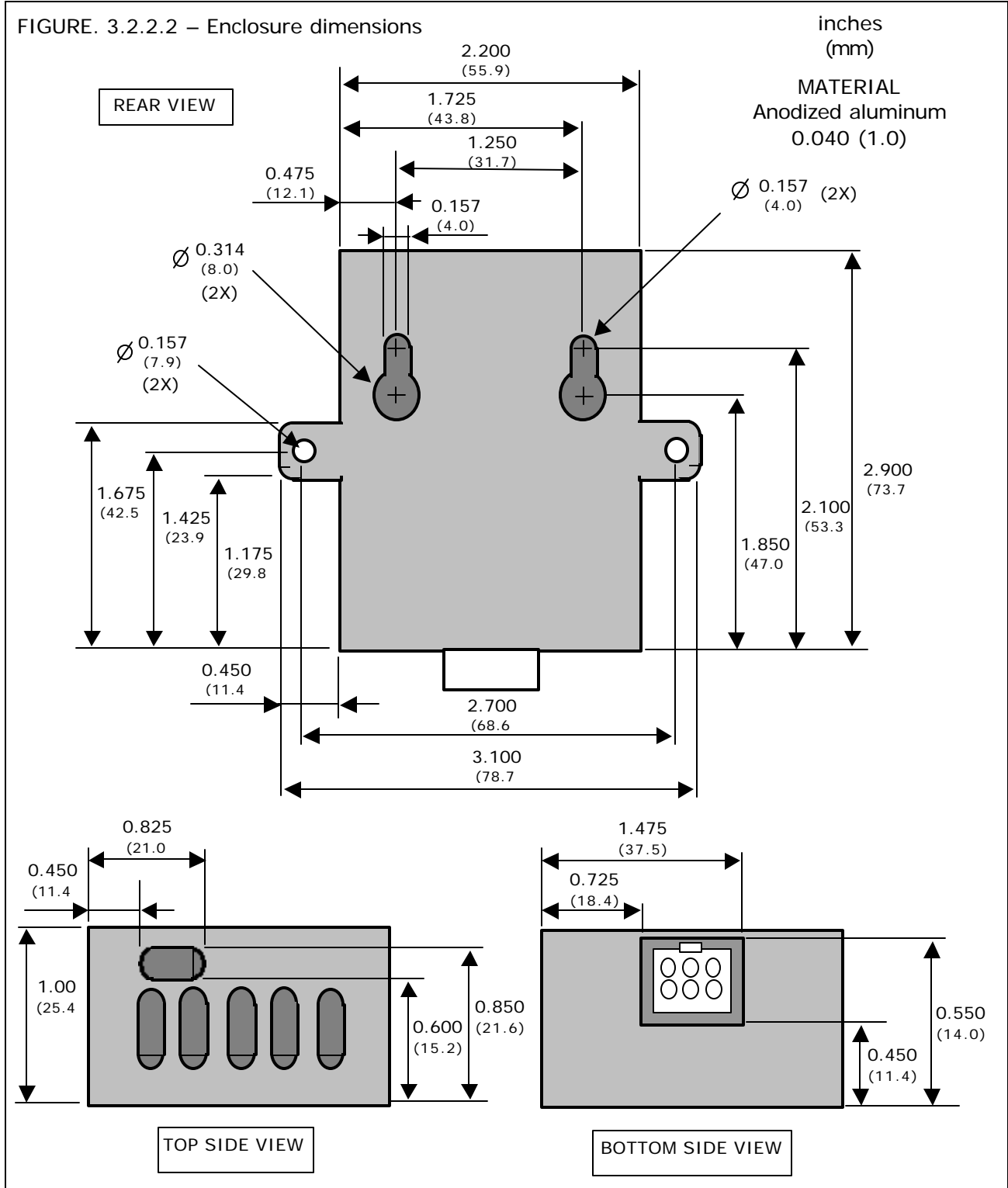
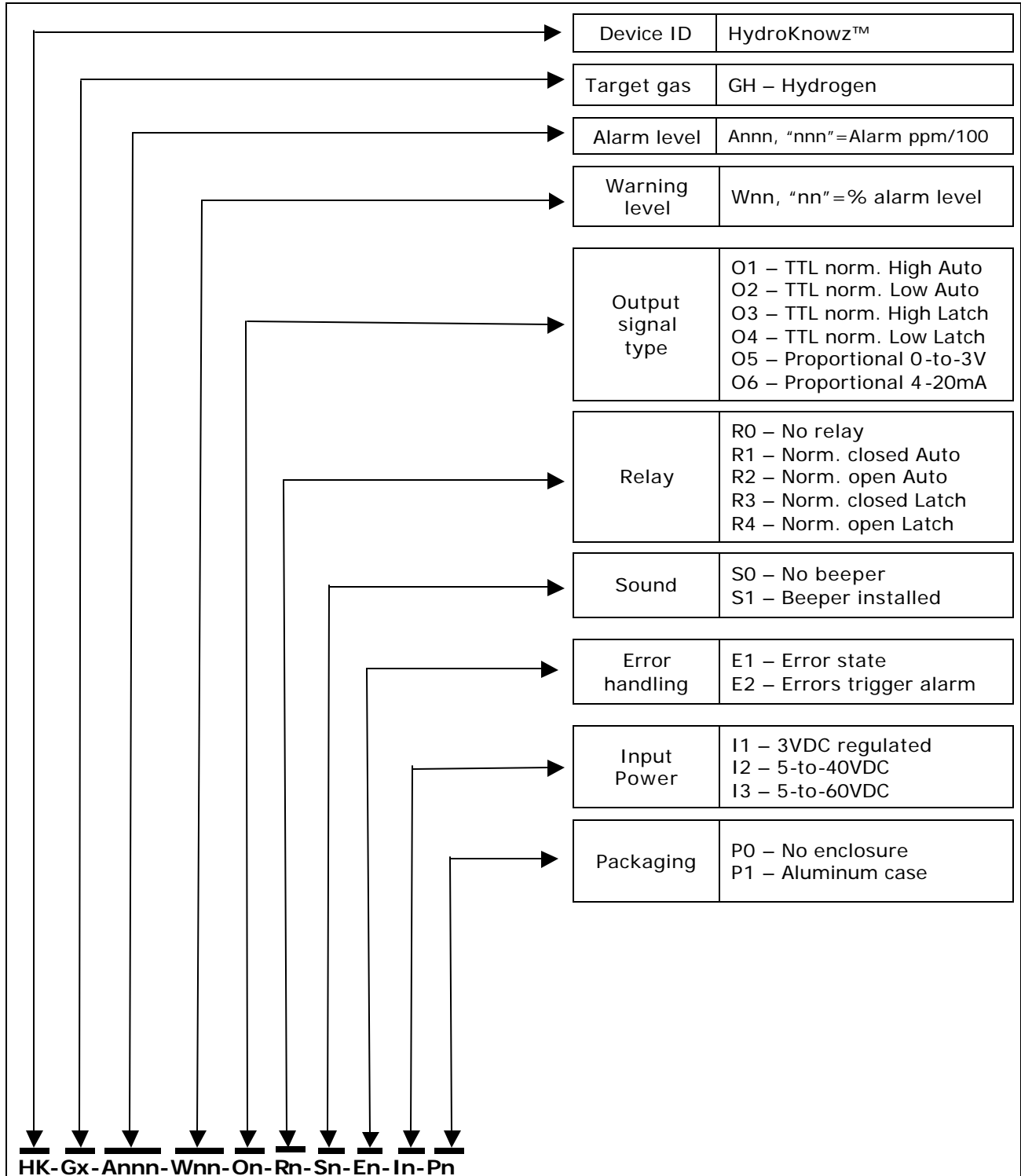

FIGURE. 3.2.2.2 – Enclosure dimensions



4 – SALES & TECHNICAL SUPPORT

4.1 – PART NUMBERING



4.2 – CONTACT INFORMATION

	CORPORATE OFFICE:	Neodym Technologies Inc. #711-675 West Hastings Street Vancouver, British Columbia Canada V6B 1N2
	TELEPHONE:	Toll-free: 1-877-723-5400 (North America) International: +1-604-939-5544 FAX: +1-604-939-4153
	INTERNET:	Corporate website: www.neosafe.com www.neodymsystems.com
	EMAIL:	Sales: sales@neodymsystems.com Technical Support: engineering@neodymsystems.com

5. – DOCUMENT REVISION HISTORY

DATE	VERSION	AUTHOR	DESCRIPTION
2007.01.02	1.0.0	JK	First release
2007.01.19	1.0.1	JK	<ul style="list-style-type: none">• Amend output DAC resolution from 8 to 10 bits• Amend 4-20mA resolution from 100 to 120 ppm• Revise sections 1.4.1 and 1.4.2 (Output Signal)• Revise reading range and resolution in section 1.6• Revise alarm level part no. spec. in section 4.1